

“QD” BUSHING

BUSHINGS & HUBS

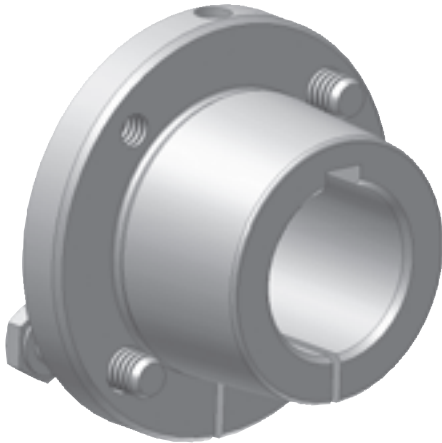

DID YOU KNOW THAT...

- All Bushings up to sizes M, and those with a shallow keyseat, are manufactured in DUCTILE iron, a stronger material offering numerous advantages
- All sizes have a set screw over the keyway to secure the key which is advantageous in vertical applications
- 100% interchangeable with licensed manufacturer's products
- Available in inches & metric sizes
- Available “Short” for weld-on hubs
- Full, not partial split

HOW TO ORDER

EXAMPLE: **SFX1-1/16**

SF

X1-1/16

SF: BUSHING SIZE

X1-1/16: BORE SIZE (1-1/16")

Inch bore sizes are designated with the whole inch followed by the fraction. For example, a 1.5" diameter bore would be 1-1/2. Metric bore sizes are designated with “MM” after the metric dimension (X25MM).

TAPERED, PRECISION FIT.

Precision machining of the tapered bore in the hub of the “QD” rim and the tapered mating surface of the bushing insures a snug, precision fit between rim and bushing. Tightening the cap screws draws the sheave up tight on the bushing - Baldor•Maska® “QD” Bushings and Sheaves are true running.

FULL - NOT PARTIAL SPLIT.

This feature, together with the tapered, precision fit of rim and bushing, enables the “QD” Bushing to compress evenly through the overall bushing length, thus gripping the shaft with tremendous pressure, the equivalent of a press fit on the shaft. And the full split makes it just as easy to install “QD” Sheaves on all standard size shafts as it is to install them on shafts which may be slightly oversized or slightly undersized.

EASY TO INSTALL, EASY TO REMOVE.

To install Baldor•Maska® “QD” Sheaves, the cap screws are used as pull-wrench only - no additional leverage is necessary. To remove “QD” Sheaves, the cap screws are taken out and used as jack screws. A few quick turns on each screw, and the tight grip of the bushing on the shaft is easily broken.

SET SCREW OVER THE KEY.

Once the correct position of the “QD” Sheave on the shaft is determined, tightening the set screw in the bushing flange down on the key will hold the bushing in this position while the pull-up bolts are tightened. This set screw holds the key in place on the shaft during drive operation - an especially desirable feature on drives that have vertical shafts facing down. Available on all “QD” bushings except W AND S.

FULLY INTERCHANGEABLE WITH OTHER “QD” BUSHINGS.

As in the case of Baldor•Maska® “QD” Sheaves, the “QD” Bushings also conform to standardized “QD” dimensions and sheave types. Because of this feature, any “QD” Stock Bushing may be interchanged with the same size bushing that other “QD” manufacturers produce.

“QD” bushings is a registered trademark and manufactured by Baldor under license.

“QD” BUSHING MOUNTING

DID YOU KNOW THAT...

- QD Bushings can be mounted either way
- Capscrews are always accessible from the outside

IMPORTANT REMINDER



DRY MOUNTING: Do not use lubricants or antiseize compounds on bushing and hub mounting area.

STANDARD MOUNTING

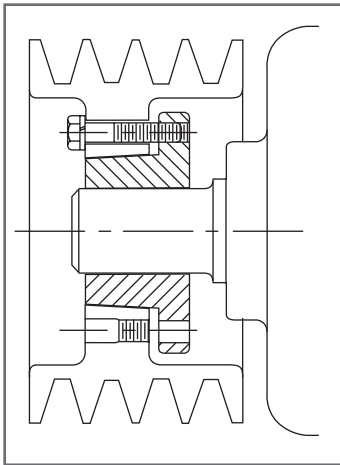

STANDARD - BUSHING FLANGE TOWARD MACHINE OR MOTOR

1. Align tapped holes in bushing flange with drilled holes in sheave hub.
2. Insert capscrews through drilled holes in sheave hub and thread loosely into tapped holes in bushing flange.
3. Position assembly on shaft and tighten capscrews progressively and uniformly.

TO REMOVE

1. Remove capscrews and thread into tapped holes in sheave hub. Tighten progressively until bushing is free from sheave taper.
2. Remove assembly from shaft.

REVERSE MOUNTING

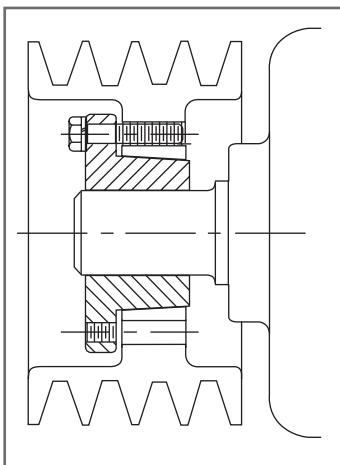

REVERSE - BUSHING FLANGE AWAY FROM MACHINE OR MOTOR

1. Align drilled holes in bushing flange with tapped holes in sheave hub.
2. Insert capscrews through drilled holes in bushing flange and thread loosely into tapped holes in sheave hub.
3. Position assembly on shaft and tighten capscrews progressively and uniformly.

TO REMOVE

1. Remove capscrews and thread into tapped holes in bushing flange. Tighten progressively until bushing is free from sheave taper.
2. Remove assembly from shaft.

“QD” BUSHING PROPER WRENCH TORQUE

TIGHTENING “IMPORTANT”

Tighten screws evenly and progressively. Never allow the sheave to be drawn in contact with the flange of the bushing. If extreme screw tightening forces are applied, excess pressures will be created in the hub of the mounted sheave which may cause it to crack.

PROPER WRENCH TORQUE TO TIGHTEN SCREWS

Bushing Size	Screw size Inches	Torque Wrench Ft-Lbs	Open end or socket wrench		Torque Capacity In-Lbs
			Length Inches	Pull (LBS)	
L	1/4	6	4	18	1,200
JA	# 10	5	4	15	1,000
SH	1/4	9	4	27	3,500
SDS-SD	1/4	9	4	27	5,000
SK	5/16	15	6	30	7,000
SF	3/8	30	6	60	11,000
E	1/2	60	12	60	20,000
F	9/16	75	12	75	30,000
J	5/8	135	15	108	45,000
M	3/4	225	15	180	85,000
N	7/8	300	15	240	150,000
P	1	450	18	300	250,000
W	1 1/8	600	24	300	375,000
S	1 1/4	750	30	300	625,000

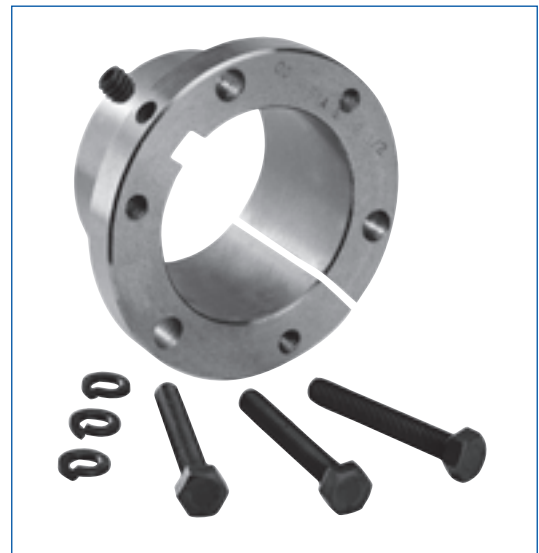

BUSHINGS & HUBS

SET SCREW TIGHTENING TORQUES AND AXIAL LOADS

Set Screw Size	Socket / Allen Key Size (Across Flat)	Recommended Tightening Torque		Set Screw Axial Load (± 30%)			
				Cup Point		Knurled Point	
		Newton - Meter (Nm)	LBF - Inches	Newtons (N)	LBF	Newtons (N)	LBF
#10 - 24	3/32	3.62	32	1500	340	2225	500
1/4 - 20	1/8	6.8	60	2500	560	3650	820
5/16 - 18	5/32	12.4	110	3500	785	5110	1150
3/8 - 16	3/16	22.6	200	4500	1010	6580	1480
1/2 - 13	1/4	45.2	400	9000	2025	13230	2975
5/8 - 11	5/16	97.2	860	12000	2720	17800	4000

Note: For axial loads in excess of the values listed, a shouldered shaft against the face of the inner ring is recommended.

“QD” BUSHINGS BORE AND KEYSEAT DIMENSIONS

BUSHINGS & HUBS

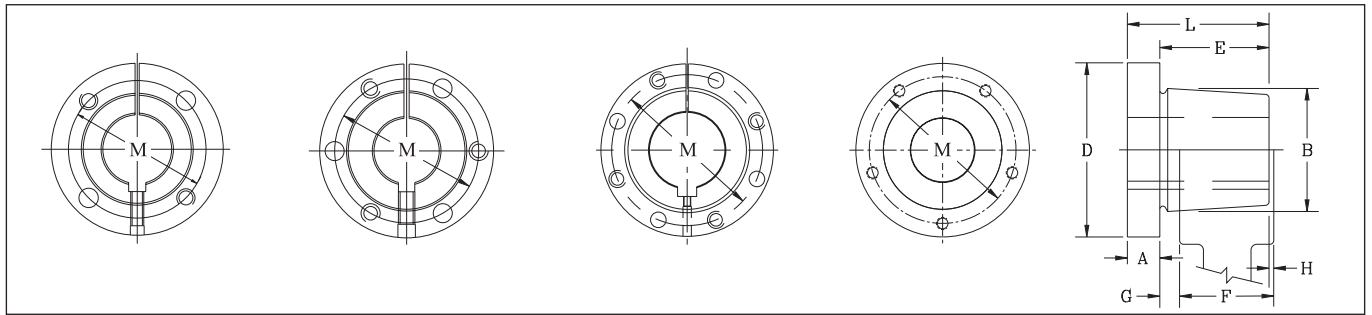

Bushing
“L”
(“H” - Cross Reference)

Bushing
“JA to J” Inclusive

Bushing
“M to W” Inclusive

Bushing “S”

Taper 3/4” per FT on Diameter - B -

DIMENSIONS

Bushing Size	List Price \$	Dimensions - Inches									Cap Screws Required NC Grade 5	Set Screw Dimensions	Bore Range		Approx. Weight Pounds
		A	B	D	E	F	G	H	L	Bolt Circle M			Min.	Max.	
L	9.00	11/32	1 5/8	2 1/2	1	29/32	3/16	3/32	1 11/32	2	2=1/4X7/8	10-24 UNC x 1/4"	3/8	1 1/2	0.7
JA	10.90	5/16	1 3/8	2	11/16	5/8	13/64	9/64	1	1 21/32	3=10-24X1	10-24 UNC x 1/4"	1/2	1 1/4	0.4
SH	14.90	3/8	1 7/8	2 11/16	7/8	3/4	1/4	1/8	1 1/4	2 1/4	3=1/4X1 3/8	1/4-20 UNC x 1/4"	1/2	1 11/16	0.9
SDS	17.30	7/16	2 3/16	3 3/16	7/8	3/4	1/4	1/8	1 5/16	2 11/16	3=1/4X1 3/8	1/4-20 UNC x 1/4"	1/2	2	1.3
SD	20.80	7/16	2 3/16	3 3/16	1 3/8	1 1/4	1/4	1/8	1 13/16	2 11/16	3=1/4X1 7/8	1/4-20 UNC x 1/4"	1/2	2	1.6
SK	26.80	1/2	2 13/16	3 7/8	1 3/8	1 1/4	5/16	3/16	1 7/8	3 5/16	3=5/16X2	1/4-20 UNC x 1/4"	1/2	2 5/8	2.7
SF	33.00	1/2	3 1/8	4 5/8	1 1/2	1 1/4	5/16	1/16	2	3 7/8	3=3/8X2	5/16-18 UNC x 3/8"	1/2	2 15/16	3.9
E	69.20	3/4	3 27/32	6	1 7/8	1 5/8	5/16	1/16	2 5/8	5	3=1/2X2 3/4	3/8-16 UNC x 3/8"	7/8	3 1/2	8.5
F	128.00	13/16	4 7/16	6 5/8	2 13/16	2 1/2	13/32	3/32	3 5/8	5 5/8	3=9/16X3 5/8	3/8-16 UNC x 3/8"	1	4	13.3
J	160.00	1	5 5/32	7 1/4	3 1/2	3 3/16	13/32	3/32	4 1/2	6 1/4	3=5/8X4 1/2	3/8-16 UNC x 3/8"	1 7/16	4 1/2	20.8
M	320.00	1 1/4	6 1/2	9 1/8	5 1/2	5 3/16	13/32	3/32	6 3/4	7 7/8	4=3/4X7	3/8-16 UNC x 1/2"	2	5 1/2	48.5
N	560.00	1 1/2	7	10	6 5/8	6 1/4	9/16	3/16	8 1/8	8 1/2	4=7/8X8	1/2-13 UNC x 5/8"	2 3/4	6	62.1
P	840.00	1 3/4	8 1/4	11 3/4	7 5/8	7 1/4	5/8	1/4	9 3/8	10	4=1X9 1/2	5/8-11 UNC x 1 1/4"	2 15/16	7	108.8
W	1480.00	2	10 7/16	15	9 3/8	9	5/8	1/4	11 3/8	12 3/4	4=1 1/8X11 1/2	1-8 UNC x 1 1/2"	4 1/4	8-1/2	218.9
S	3480.00	3 1/4	12 1/8	17 3/4	12 1/2	12	13/16	5/16	15 3/4	15	5=1 1/4X15 1/2	1 1/4-7 UNC x 2"	5 1/2	10	382.0
SX5**	3132.00	3 1/4	12 1/8	17 3/4	12 1/2	12	13/16	5/16	15 3/4	15	5=1 1/4X15 1/2	1 1/4-7 UNC x 2"	-	-	382.0
SX7-1/2**	3132.00	3 1/4	12 1/8	17 3/4	12 1/2	12	13/16	5/16	15 3/4	15	5=1 1/4X15 1/2	1 1/4-7 UNC x 2"	-	-	382.0

Refer to page 10 for Cap screw torque ratings
Note: Approx. weight in lbs. for an average size bore.

** RB = Rough bore

Note: Tapered Bushings are available from stock in all bores and keyseats listed below. In some cases, as the bore increases in diameter, a shallow keyseat is provided - due to insufficient metal thickness. When this happens, Baldor furnishes the correct rectangular key (inches or imperial bore only). This does not affect the bushing's ability to transmit the load. The rectangular key, or flat key as some call it, fits into the standard keyway in the shaft.

STANDARD STOCK BORES (INCHES)

Bushing	Stock Bore	Keyseat
L	3/8 · 7/16	No K.S.
	1/2° · 9/16	1/8 x 1/16
	5/8 · 11/16 · 3/4 · 13/16 · 7/8	3/16 x 3/32
	15/16 · 1 · 1 1/16 · 1 1/8	1/4 x 1/8
	1 3/16 · 1 1/4	1/4 x 1/8
	1 5/16 · 1 3/8	5/16 x 1/16**
	1 7/16	3/8 x 1/16**
	1 1/2	3/8 x 3/64**
JA	1/2° · 9/16	1/8 x 1/16
	5/8 · 11/16 · 3/4 · 13/16 · 7/8	3/16 x 3/32
	15/16 · 1	1/4 x 1/8
	1 1/16 · 1 1/8 · 1 3/16	1/4 x 1/16**
	1 1/4	1/4 x 1/32**
SH	1/2° · 9/16	1/8 x 1/16
	5/8 · 11/16 · 3/4 · 13/16 · 7/8	3/16 x 3/32
	15/16 · 1 · 1 1/16 · 1 1/8	1/4 x 1/8
	1 3/16 · 1 1/4	1/4 x 1/8
	1 5/16 · 1 3/8	5/16 x 5/32
	1 7/16	3/8 x 1/8**
	1 1/2 · 1 9/16 · 1 5/8	3/8 x 1/16**
	1 11/16	No K.S.
SDS	1/2° · 9/16	1/8 x 1/16
	5/8 · 11/16 · 3/4 · 13/16 · 7/8	3/16 x 3/32
	15/16 · 1 · 1 1/16 · 1 1/8	1/4 x 1/8
	1 3/16 · 1 1/4	1/4 x 1/8
	1 5/16 · 1 3/8	5/16 x 5/32
	1 7/16 · 1 1/2 · 1 9/16 · 1 5/8	3/8 x 3/16
	1 11/16 · 1 3/4	3/8 x 1/8**
	1 13/16	1/2 x 1/8**
	1 7/8 · 1 15/16	1/2 x 1/16**
	2	No K.S.
SD	1/2° · 9/16	1/8 x 1/16
	5/8 · 11/16 · 3/4 · 13/16 · 7/8	3/16 x 3/32
	15/16 · 1 · 1 1/16 · 1 1/8	1/4 x 1/8
	1 3/16 · 1 1/4	1/4 x 1/8
	1 5/16 · 1 3/8	5/16 x 5/32
	1 7/16 · 1 1/2 · 1 9/16 · 1 5/8	3/8 x 3/16
	1 11/16 · 1 3/4	3/8 x 1/8**
	1 13/16	1/2 x 1/8**
	1 7/8 · 1 15/16	1/2 x 1/16**
	2	No K.S.

Bushing	Stock Bore	Keyseat
SK	1/2° · 9/16	1/8 x 1/16
	5/8 · 11/16 · 3/4 · 13/16 · 7/8	3/16 x 3/32
	15/16 · 1 · 1 1/16 · 1 1/8	1/4 x 1/8
	1 3/16 · 1 1/4	1/4 x 1/8
	1 5/16 · 1 3/8	5/16 x 5/32
	1 7/16 · 1 1/2 · 1 9/16 · 1 5/8	3/8 x 3/16
	1 11/16 · 1 3/4	3/8 x 3/16
	1 13/16 · 1 7/8 · 1 15/16 · 2	1/2 x 1/4
	2 1/16 · 2 1/8	1/2 x 1/4
	2 3/16 · 2 1/4	1/2 x 1/8**
	2 1/4KW5/8* · 2 5/16 · 2 3/8	5/8 x 1/8**
SF	1/2° · 9/16	1/8 x 1/16
	5/8 · 11/16 · 3/4 · 13/16 · 7/8	3/16 x 3/32
	15/16 · 1 · 1 1/16 · 1 1/8	1/4 x 1/8
	1 3/16 · 1 1/4	1/4 x 1/8
	1 5/16 · 1 3/8	5/16 x 5/32
	1 7/16 · 1 1/2 · 1 9/16 · 1 5/8	3/8 x 3/16
	1 11/16 · 1 3/4	3/8 x 3/16
	1 13/16 · 1 7/8 · 1 15/16 · 2	1/2 x 1/4
	2 1/16 · 2 1/8 · 2 3/16 · 2 1/4	1/2 x 1/4
	2 1/4KW5/8*	5/8 x 5/16
	2 5/16 · 2 3/8 · 2 7/16 · 2 1/2	5/8 x 3/16**
SDS	2 9/16 · 2 5/8 · 2 11/16 · 2 3/4	5/8 x 1/16**
	2 13/16 · 2 7/8	3/4 x 1/16**
	2 15/16	3/4 x 1/32**

* Bushings with 1/2" wide keyway will be shipped unless the 5/8" wide keyway is specified when ordering.

** Shallow keyseat Baldor supplies the key

o All 1/2" bore sizes are stocked without a keyseat. A standard keyseat 1/8" X 1/16" is available upon request.

Note: All Bushings up to sizes M, and those with a shallow keyseat, are manufactured in DUCTILE iron

STANDARD STOCK BORES (INCHES)

BUSHINGS & HUBS

Bushing	Stock Bore	Keyseat
E	7/8	3/16 X 3/32
	15/16 · 1 · 1 1/16 - 1 1/8	1/4 x 1/8
	1 3/16 · 1 1/4	1/4 x 1/8
	1 5/16 · 1 3/8	5/16 x 5/32
	1 7/16 · 1 1/2 · 1 9/16 · 1 5/8	3/8 x 3/16
	1 11/16 · 1 3/4	3/8 x 3/16
	1 13/16 · 1 7/8 · 1 15/16 · 2	1/2 x 1/4
	2 1/16 · 2 1/8	1/2 x 1/4
	2 3/16 · 2 1/4	1/2 x 1/4
	2 1/4KW5/8* · 2 5/16 · 2 3/8	5/8 x 5/16
	2 7/16 · 2 1/2 · 2 9/16 · 2 5/8	5/8 x 5/16
	2 11/16 · 2 3/4	5/8 x 5/16
	2 13/16 · 2 7/8	3/4 x 3/8
	2 15/16 · 3 · 3 1/16 · 3 1/8	3/4 x 1/8**
	3 3/16 · 3 1/4	3/4 x 1/8**
3 5/16 · 3 3/8 · 3 7/16 · 3 1/2	7/8 x 1/16**	
F	1-1 1/16 · 1 1/8 · 1 3/16 · 1 1/4	1/4 x 1/8
	1 5/16 · 1 3/8	5/16 x 5/32
	1 7/16 · 1 1/2 · 1 9/16 · 1 5/8	3/8 x 3/16
	1 11/16 · 1 3/4	3/8 x 3/16
	1 13/16 · 1 7/8 · 1 15/16 · 2	1/2 x 1/4
	2 1/16 · 2 1/8 · 2 3/16 · 2 1/4	1/2 x 1/4
	2 1/4KW5/8* · 2 5/16 · 2 3/8	5/8 x 5/16
	2 7/16 · 2 1/2 · 2 9/16 · 2 5/8	5/8 x 5/16
	2 11/16 · 2 3/4	5/8 x 5/16
	2 13/16 · 2 7/8 · 2 15/16 · 3	3/4 x 3/8
	3 1/16 · 3 1/8 · 3 3/16 · 3 1/4	3/4 x 3/8
	3 5/16 · 3 3/8 · 3 7/16 · 3 1/2	7/8 x 3/16**
	3 9/16 · 3 5/8 · 3 11/16 · 3 3/4	7/8 x 3/16**
	3 13/16 · 3 7/8 · 3 15/16	1 x 1/8**
	4	No K.S.
J	1 7/16 · 1 1/2 · 1 9/16 · 1 5/8	3/8 x 3/16
	1 11/16 · 1 3/4	3/8 x 3/16
	1 13/16 · 1 7/8 · 1 15/16 · 2	1/2 x 1/4
	2 1/8 · 2 3/16 · 2 1/4	1/2 x 1/4
	2 5/16 · 2 3/8 · 2 7/16 · 2 1/2	5/8 x 5/16
	2 9/16 · 2 5/8 · 2 11/16	5/8 x 5/16
	2 3/4	5/8 x 5/16
	2 13/16 · 2 7/8 · 2 15/16 · 3	3/4 x 3/8
	3 1/16 · 3 1/8 · 3 3/16 · 3 1/4	3/4 x 3/8
	3 5/16 · 3 3/8 · 3 7/16 · 3 1/2	7/8 x 7/16
	3 5/8 · 3 11/16 · 3 3/4	7/8 x 7/16
	3 13/16	1 x 1/2
	3 7/8 · 3 15/16	1 x 3/8**
	4 · 4 1/8 · 4 3/16 · 4 1/4	1 x 1/8**
	4 3/8 · 4 7/16 · 4 1/2	1 x 1/8**

* Bushings with 1/2" wide keyway will be shipped unless the 5/8" wide keyway is specified when ordering.
 ** Shallow keyseat. Baldor supplies the key
Note: All Bushings up to sizes M are manufactured in ductile iron
 § Others sizes manufactured in ductile iron.

Additional bore sizes available upon request.

Bushing	Stock Bore	Keyseat	
M	2 · 2 1/8 · 2 3/16 · 2 1/4	1/2 x 1/4	
	2 3/8 · 2 7/16 · 2 1/2 · 2 5/8	5/8 x 5/16	
	2 11/16 · 2 3/4	5/8 x 5/16	
	2 13/16 · 2 7/8 · 2 15/16 · 3	3/4 x 3/8	
	3 1/8 · 3 3/16 · 3 1/4	3/4 x 3/8	
	3 3/8 · 3 7/16 · 3 1/2	7/8 x 7/16	
	3 5/8 · 3 11/16 · 3 3/4	7/8 x 7/16	
	3 13/16 · 3 7/8 · 3 15/16 · 4	1 x 1/2	
	4 1/8 · 4 3/16 · 4 1/4 · 4 5/16	1 x 1/2	
	4 3/8 · 4 7/16 · 4 1/2	1 x 1/2	
	4 5/8 · 4 11/16 · 4 3/4	1 1/4 x 5/8	
	4 7/8 · 4 15/16 · 5 · 5 1/8	1 1/4 x 1/4**	
	5 3/16 · 5 1/4 · 5 5/16	1 1/4 x 1/4**	
	5 3/8 · 5 7/16 · 5 1/2	1 1/4 x 1/4**	
	N	2 3/4	5/8 x 5/16
2 15/16 · 3 · 3 1/4		3/4 x 3/8	
3 5/16 · 3 3/8 · 3 7/16 · 3 1/2		7/8 x 7/16	
3-5/8 · 3 3/4		7/8 x 7/16	
3 7/8 · 3 15/16 · 4 · 4 3/16		1 x 1/2	
4 1/8 · 4 1/4 · 4 3/8 · 4 7/16		1 x 1/2	
4 1/2		1 x 1/2	
4 9/16 · 4 5/8 · 4 11/16		1 1/4 x 5/8	
4 3/4 · 4 7/8 · 4 15/16 · 5		1 1/4 x 5/8	
5 1/8 · 5 3/16 · 5 1/4		1 1/4 x 1/4**§	
5 5/16 · 5 3/8 · 5 7/16 · 5 1/2		1 1/4 x 1/4**§§	
5 3/4		1 1/2 x 1/4**§§	
5 7/8		1 1/2 x 1/4**§	
5 15/16-6		1 1/2 x 1/8**§	
P		2 15/16 · 3 1/4	3/4 x 3/8
	3 3/8 · 3 7/16 · 3 1/2	7/8 x 7/16	
	3 5/8 · 3 3/4	7/8 x 7/16	
	3 7/8 · 3 15/16 · 4 · 4 1/4	1 x 1/2	
	4 3/8 · 4 7/16 · 4 1/2	1 x 1/2	
	4 5/8 · 4 11/16 · 4 3/4	1 1/4 x 5/8	
	4 7/8 · 4 15/16 · 5 · 5 1/8	1 1/4 x 5/8	
	5 3/16 · 5 1/4 · 5 5/16	1 1/4 x 5/8	
	5 3/8 · 5 7/16 · 5 1/2	1 1/4 x 5/8	
	5 3/4 · 5 7/8 · 5 15/16 · 6	1 1/2 x 1/4**§	
	6 1/16 · 6 1/4 · 6 7/16	1 1/2 x 1/4**§	
	6 1/2	1 1/2 x 1/4**§	
	6 3/4 · 6 15/16 · 7	1 3/4 x 1/8**§	
	W	4 1/4 · 4 7/16 · 4 1/2	1 x 1/2
		4 5/8 · 4 3/4 · 4 7/8 · 4 15/16	1 1/4 x 5/8
5 · 5 3/8 · 5 7/16 · 5 1/2 · 5 11/16		1 1/4 x 5/8	
5 3/4 · 5 7/8 · 5 15/16 · 6		1 1/4 x 5/8	
6 1/4 · 6 7/16 · 6 1/2		1 1/2 x 3/4	
6 3/4 · 6 7/8 · 6 15/16 · 7		1 1/2 x 3/4	
7 1/4 · 7 3/8 · 7 7/16 · 7 1/2		1 3/4 x 3/4	
7 3/4 · 7 7/8		2 x 1/4**	
8 · 8 1/2		2 x 1/4** §	
S		5 1/2	1 1/4 x 5/8
		5 3/4 · 5 7/8 · 5 15/16 · 6	1 1/2 x 3/4
		6 1/4 · 6 7/16 · 6 1/2	1 1/2 x 3/4
		6 3/4 · 6 15/16 · 7 · 7 1/4 · 7 1/2	1 3/4 x 3/4
		7 3/4 · 7 7/8 · 8 · 8 1/4	2 x 3/4
		8 1/2 · 8 3/4 · 8 7/8 · 9	2 x 3/4
	9 1/4 · 9 3/8 · 9 1/2	2 1/2 x 1/2**§	
	9 3/4	2 1/2 x 3/8**§	
	9 7/8 · 10	2 1/2 x 1/4**§§	
	S-RB	SX5RB - SX7-1/2RB	No K.S.
		Stocked in 2 rough bore sizes; can be rebored from 5 1/2" to 10" max.	

Note: In metric bores, a key is not supplied for shallow keyway. The metric system does not refer to keyseat or keyway dimensions as does the English system; instead, dimensions are given for the key itself. For nominal diameter up to 22 mm, the key is square in shape. For nominal diameter over 22 mm, the key is rectangular in shape. This meets ISO standards.

STANDARD STOCK BORES (MILLIMETERS)

Bushing	Stock Bore	Keyseat	Key
L	14 · 15 · 16	5 x 2.3	5 x 5
	18 · 19 · 20 · 22	6 x 2.8	6 x 6
	24 · 25 · 28 · 30	8 x 3.3	8 x 7
	32	10 x 3.3	10 x 8
	35 · 38	10 x 1.3**	10 X 6**
JA	14 · 15 · 16	5 x 2.3	5 x 5
	18 · 19 · 20 · 22	6 x 2.8	6 x 6
	24 · 25	8 x 2.3**	8 x 6**
	28	8 x 1.3**	8 x 5**
SH	14 · 15 · 16	5 x 2.3	5 x 5
	18 · 19 · 20 · 22	6 x 2.8	6 x 6
	24 · 25 · 28 · 30	8 x 3.3	8 x 7
	32 · 35	10 x 3.3	10 x 8
	38	10 x 2.3**	10 x 7**
	40	No. k.s.	No K.S.
SDS	14 · 15 · 16	5 x 2.3	5 x 5
	18 · 19 · 20 · 22	6 x 2.8	6 x 6
	24 · 25 · 28 · 30	8 x 3.3	8 x 7
	32 · 35 · 38	10 x 3.3	10 x 8
	40 · 42	12 x 3.3	12 x 8
SD	14 · 15 · 16	5 x 2.3	5 x 5
	18 · 19 · 20 · 22	6 x 2.8	6 x 6
	24 · 25 · 28 · 30	8 x 3.3	8 x 7
	32 · 35 · 38	10 x 3.3	10 x 8
	40 · 42	12 x 3.3	12 x 8
SK	14 · 15 · 16	5 x 2.3	5 x 5
	18 · 19 · 20 · 22	6 x 2.8	6 x 6
	24 · 25 · 28 · 30	8 x 3.3	8 x 7
	32 · 35 · 38	10 x 3.3	10 x 8
	40 · 42	12 x 3.3	12 x 8
	45 · 48 · 50	14 x 3.8	14 x 9
	55	16 x 4.3	16 x 10
60	18 x 3.4**	18 x 10**	
SF	25 · 28 · 30	8 x 3.3	8 x 7
	32 · 35 · 38	10 x 3.3	10 x 8
	40 · 42	12 x 3.3	12 x 8
	45 · 48 · 50	14 x 3.8	14 x 9
	55	16 x 4.3	16 x 10
60 · 65	18 x 4.4	18 x 11	

Bushing	Stock Bore	Keyseat	Key
E	35 · 38	10 x 3.3	10 x 8
	40 · 42	12 x 3.3	12 x 8
	45 · 48 · 50	14 x 3.8	14 x 9
	55	16 x 4.3	16 x 10
	60 · 65	18 x 4.4	18 x 11
	70 · 75	20 x 4.9	20 x 12
	80	22 x 5.4	22 x 14
F	45 · 48 · 50	14 x 3.8	14 x 9
	55	16 x 4.3	16 x 10
	60 · 65	18 x 4.4	18 x 11
	70 · 75	20 x 4.9	20 x 12
	80 · 85	22 x 5.4	22 x 14
	90 · 95	25 x 5.4	25 x 14
100	No. k.s.	No K.S.	
J	50	14 x 3.8	14 x 9
	55	16 x 4.3	16 x 10
	60 · 65	18 x 4.4	18 x 11
	70 · 75	20 x 4.9	20 x 12
	80 · 85	22 x 5.4	22 x 14
	90 · 95	25 x 5.4	25 x 14
	100	28 x 6.4	28 x 16
	110	28 x 5.4**	28 x 15**
115	32 x 1.2**	32 x 11.8 **	
M	90	25 x 5.4	25 x 14
	100	28 x 6.4	28 x 16
	115 · 120	32 x 7.4	32 x 18
N	90	25 x 5.4	25 x 14
	100 · 110	28 x 6.4	28 x 16
	120	32 x 7.4	32 x 18
P	130	32 x 7.4	32 x 18
	150	36 x 8.4	36 x 20

Additional bore sizes available upon request.

** Shallow keyseat / key (key not supplied)
Note: All Bushings up to sizes M are manufactured in ductile iron

BUSHINGS & HUBS