

8000 SERIES



DID YOU KNOW THAT...

- Stock Sizes - 1 and 2 grooves up to 25 HP
- Both 1 and 2 groove adjustable sheaves permit variations of as much as 30% in speed when used with a fixed diameter sheave
- Detailed Cross-Over Chart on pages 187-188
- Available in metric bores
- Larger sizes come with 2 set screws
- Other special bores are available, call for delivery terms

IMPORTANT REMINDER



Applications with a speed superior to 5000 ft./min. may require more accurate balancing.

Specify sheave and required bore diameter when ordering.

HOW TO ORDER

EXAMPLE: 8600X1-3/8

8600

X1-3/8

8600: ADJUSTABLE PITCH SHEAVE SIZE
The first digit stands for 8000 series. Last three digits represent the approximate outside diameter (6.00)

X1-3/8: BORE SIZE (1 3/8")
Bore size: Metric bore sizes are designated with "MM" after the metric dimension (X 25MM). Inch bore sizes are designated with the whole inch followed by the fraction. For example, a 1.5" diameter bore would be 1-1/2.

Pulley Adjustment

Modify the sheave pitch diameter by rotating the adjustable flange on the threaded hub of the pulley. Once the required diameter is obtained, tighten the adjusting screw(s) on one of the two flat surfaces.

To obtain the same pitch diameter in both grooves of the D8000 series, tighten both movable flanges against the central flange, make trace marks on both flanges, then rotate both flanges the same number of turns.

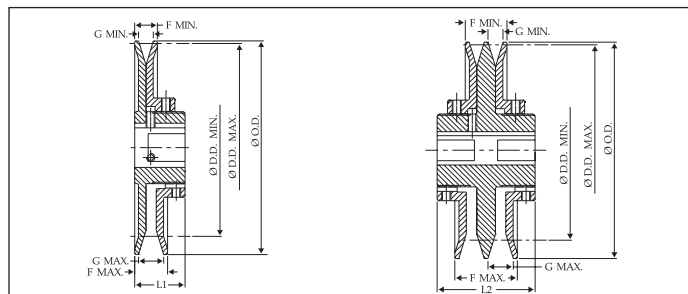

SINGLE GROOVE

DOUBLE GROOVE

DIMENSIONS 1 GROOVE

Part No.	List Price \$	O.D.	L1	F		G		Available Stock Bores	Weight (lbs)
				Max.	Min.	Max.	Min.		
8325	33.80	3.25	1 3/4	1 1/32	21/32	3/4	3/8	*1/2 · 5/8 · 3/4 · 7/8 · 1 · 1 1/8 9mm · 14mm · 19mm	2.0
8350	41.60	3.75	1 3/4	1 5/32	25/32	7/8	1/2	*1/2 · 5/8 · 3/4 · 7/8 · 1 · 1 1/8 9mm · 14mm · 19mm · 24mm · 28mm	2.0
8400	42.70	4.15	1 3/4	1 5/32	25/32	7/8	1/2	*1/2 · 5/8 · 3/4 · 7/8 · 1 · 1 1/8 12.7mm · 14mm · 19mm · 24mm · 28mm	2.5
8450 ¹	43.20	4.75	1 3/4	1 5/32	25/32	7/8	1/2	*1/2 · 5/8 · 3/4 · 7/8 · 1 · 1 1/8 12.7mm · 14mm · 19mm · 24mm · 28mm	3.1
8550 ²	67.80	5.35	1 3/4	1 9/32	25/32	1	1/2	*1/2 · 5/8 · 3/4 · 7/8 · 1 · 1 1/8 · 1 3/8 · 1 5/8 12.7mm · 14mm · 19mm · 24mm · 28mm · 38mm	4.5
8600 ²	105.40	6.00	1 3/4	1 9/32	25/32	1	1/2	5/8 · 3/4 · 7/8 · 1 · 1 1/8 · 1 3/8 · 1 5/8 12.7mm · 19mm · 24mm · 28mm · 38mm · 42mm	5.0
8670 ²	106.80	6.70	1 3/4	1 9/32	25/32	1	1/2	5/8 · 3/4 · 7/8 · 1 · 1 1/8 · 1 3/8 · 1 5/8 12.7mm · 19mm · 24mm · 28mm · 38mm · 42mm	6.0
8740 ²	153.40	7.40	1 3/4	1 9/32	25/32	1	1/2	3/4 · 7/8 · 1 · 1 1/8 · 1 3/8 · 1 5/8 24mm · 28mm · 38mm · 42mm	7.0

DIMENSIONS 2 GROOVES

Part No.	List Price \$	O.D.	L2	F		G		Available Stock Bores	Weight (lbs)
				Max.	Min.	Max.	Min.		
D8325	81.00	3.25	3 1/4	1 15/16	1 3/16	3/4	3/8	5/8 · 3/4 · 7/8 · 1 · 1 1/8 24mm · 28mm	3.5
D8350	93.20	3.75	3 3/8	2 3/16	1 7/16	7/8	1/2	5/8 · 3/4 · 7/8 · 1 · 1 1/8 28mm	4.2
D8400	100.30	4.15	3 3/8	2 3/16	1 7/16	7/8	1/2	5/8 · 3/4 · 7/8 · 1 · 1 1/8 24mm · 28mm	4.8
D8450 ¹	105.80	4.75	3 3/8	2 3/16	1 7/16	7/8	1/2	5/8 · 3/4 · 7/8 · 1 · 1 1/8 12.7mm · 24mm · 28mm	6.0
D8550 ²	123.60	5.35	3 3/8	2 7/16	1 7/16	1	1/2	3/4 · 7/8 · 1 · 1 1/8 · 1 3/8 · 1 5/8 12.7mm · 19mm · 24mm · 28mm · 38mm	9.0
D8600 ²	167.20	6.00	3 3/8	2 7/16	1 7/16	1	1/2	3/4 · 7/8 · 1 · 1 1/8 · 1 3/8 · 1 5/8 12.7mm · 24mm · 28mm · 38mm · 42mm	10.8
D8670 ²	176.80	6.70	3 3/8	2 7/16	1 7/16	1	1/2	3/4 · 7/8 · 1 · 1 1/8 · 1 3/8 · 1 5/8 12.7mm · 24mm · 28mm · 38mm · 42mm	12.8
D8740 ²	272.60	7.40	3 3/8	2 7/16	1 7/16	1	1/2	3/4 · 7/8 · 1 · 1 1/8 · 1 3/8 · 1 5/8 24mm · 28mm · 38mm · 42mm	14.8

* Supplied without keyway

¹ Comes with two set screws at 120 degrees

≤ Comes with two set screws at 120 degrees and an "H" Key

U.S. Patent N° 450 4249

Can. Patent N° 1160478

8000 SERIES

DATUM DIAMETERS

	Part No.	Datum Diameter, Inches								
		Min.	Max.	0 Turn Close	1 Turn Open	2 Turns Open	3 Turns Open	4 Turns Open	5 Turns Open	6 Turns Open
(4L) "A" Belt	8325	2.30	3.10	-	3.10	2.90	2.70	2.50	2.30	—
	8350	2.40	3.40	3.40	3.20	3.00	2.80	2.60	2.40	—
	8400	2.80	3.80	3.80	3.60	3.40	3.20	3.00	2.80	—
	8450	3.40	4.40	4.40	4.20	4.00	3.80	3.60	3.40	—
	8550	3.95	5.03	5.03	4.76	4.49	4.22	3.95	—	—
	8600	4.33	5.68	5.68	5.41	5.14	4.87	4.60	4.33	—
	8670	5.03	6.38	6.38	6.11	5.84	5.57	5.30	5.03	—
	8740	5.73	7.08	7.08	6.81	6.54	6.27	6.00	5.73	—
(5L) "B" Belt	8325	2.50	3.10	-	—	—	3.10	2.90	2.70	2.50
	8350	2.70	3.70	-	3.70	3.50	3.30	3.10	2.90	2.70
	8400	3.10	4.10	-	4.10	3.90	3.70	3.50	3.30	3.10
	8450	3.70	4.70	-	4.70	4.50	4.30	4.10	3.90	3.70
	8550	3.80	5.15	-	5.15	4.88	4.61	4.34	4.07	3.80
	8600	4.45	5.80	-	5.80	5.53	5.26	4.99	4.72	4.45
	8670	5.15	6.50	-	6.50	6.23	5.96	5.69	5.42	5.15
	8740	5.85	7.20	-	7.20	6.93	6.66	6.39	6.12	5.85
"5V" Belt	8325	-	-	-	-	--	—	—	—	—
	8350	-	-	-	-	--	—	—	—	—
	8400	-	-	-	-	--	—	—	—	—
	8450	-	-	-	-	--	—	—	—	—
	8550	4.17	5.25	-	5.25	4.98	4.71	4.44	4.17	—
	8600	4.55	5.90	-	5.90	5.63	5.36	5.09	4.82	4.55
	8670	5.25	6.60	-	6.60	6.33	6.06	5.79	5.52	5.25
	8740	5.95	7.30	-	7.30	7.03	6.76	6.49	6.22	5.95

P.D. for "A" belts = Datum Dia. "A" belts + .25"

P.D. for "B" belts = Datum Dia. "B" belts + .35"

P.D. for "5V" belts = Datum Dia. "5V" belt + .10"

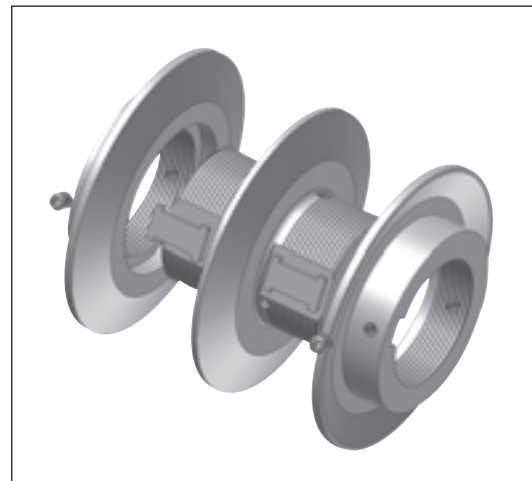
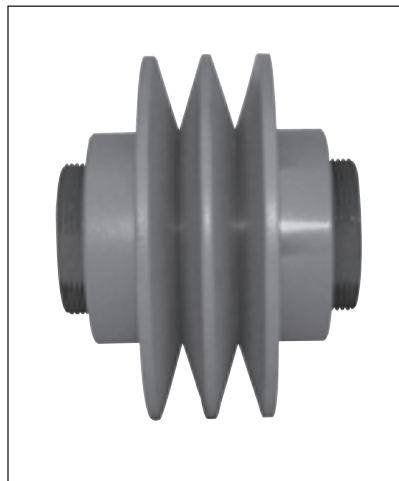

SHEAVES