

MASKAFLEX

ELASTOMERIC TIRE TYPE



Most suitable coupling for applications with shock loads, angular misalignment up to 4° and end float up to 1/4".

Fits with our QD bushing for easier installation and dismounting and has greater versatility than the fixed bore style without damaging the shaft.

DID YOU KNOW THAT...

- Superior European designed and manufactured “X-Tork” tire
- Bonded and thermally stabilized rubber with double-woven textile cords
- Multiple cables in toe that allow the element to seat perfectly and contribute to element stability & flange grip
- Ridged extremity & inner sidewalls designed for enhance grip of the flanges
- Neoprene tire elements available upon request for increased resistance to UV rays and heat

IMPORTANT REMINDER



- Maska Flex couplings are balanced to meet general industrial applications. Applications with a speed superior to 5,000 fts./min. may require more accurate balancing.
- Shaft ends can project beyond the bushing. If this occurs, allow space between shaft ends for endfloat & misalignment.
- The standard tire element in natural rubber is designed for temperatures between -42°C and +82°C.

MASKAFLEX

ELASTOMERIC TIRE TYPE



HOW TO ORDER

COMPLETE COUPLING

EXAMPLE: **MX 120**

MX 120

MX 120: COMPLETE MASKAFLEX PART NUMBER

FLANGE

EXAMPLE: **MXF 120**

MXF 120

MXF 120: MASKAFLEX FLANGE PART NUMBER

ELEMENT MATERIAL

EXAMPLE: **P120**

P120

P120: MASKAFLEX ELEMENT PART NUMBER
(TIRE)

A complete Maskaflex coupling corresponds to (2) flanges and (1) element. Specify the bore size required to order the appropriate QD bushing with it.





CROSS REFERENCES

MASKA-FLEX Maska	HI-FLEX Maurey	*PARA-FLEX Dodge	MARTIN-FLEX Martin
MX 50	50JA	PX50	F5 JA
MX 60	60SH	PX60	F6 JA
MX 70	70SH	PX70	F7 SH
MX 80	80SDS	PX80	F8 SDS
MX 90	90SK	PX90	F9 SK
MX 100	100SF	PX100	F10 SF
MX 110	110SF	PX110	F11 SF
MX 120	120E	PX120	F12 E
MX 140	140E	PX140	N/A
MX 160	N/A	PX160	N/A
MX 200	N/A	PX200	N/A

* Paraflex Couplings are designed for use with taper-lock bushings.

Flexible elastomeric element



Easy to Assemble

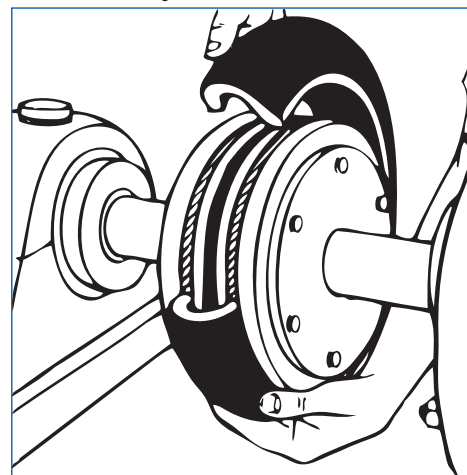

WRENCH TORQUE TO TIGHTEN SCREWS

Coupling No.	CAPSCREW	TORQUE
MX 50	1/4-20UNC x 1	96 in-lbs
MX 60	1/4-20UNC x 1-1/4	96 in-lbs
MX 70	5/16-18UNC x 1-1/2	205 in-lbs
MX 80	5/16-18UNC x 1-1/2	205 in-lbs
MX 90	3/8-16 x 1-3/4	360 in-lbs
MX 100	3/8-16 x 1-3/4	360 in-lbs
MX 110	3/8-16 x 2	360 in-lbs
MX 120	1/2-13UNC x 2-1/4	900 in-lbs
MX 140	1/2-13UNC x 2-1/2	900 in-lbs
MX 160	5/8-11UNC x 3 Grade 8	1800 in-lbs
MX 200	5/8-11UNC x 4 Grade 8	1800 in-lbs

DIMENSIONS

Complete Coupling Part No	List price w/o Bushing	Bush. Size	Max. Bore	Type	Dimensions (inches)							Weight (lbs)		
	Complete Coupling				A	B	C	D	E	F	G	Complete	Flange	Tire
MX 50**	114.00	JA	1 1/4	1	5 1/4	3 7/8	3 23/32	3 17/32	7/8	*	1 17/32	4.7	2.1	.5
MX 60	151.00	SH	1 5/8	1	6 1/2	4 23/32	4 1/2	4 9/32	1 9/32	*	1 25/32	8.0	3.5	1.0
MX 70	201.00	SDS	1 15/16	1	7 3/8	4 17/32	4 5/16	4 1/8	1 1/2	*	1 1/2	10.7	4.7	1.3
MX 80	265.00	SK	2 1/2	1	8 3/8	5 13/16	5 17/32	5 1/4	1 1/2	*	1 1/2	15.5	6.9	1.7
MX 90	335.00	SK	2 1/2	1	9 1/4	5 7/8	5 9/16	5 5/16	1 17/32	*	1 9/16	22.0	10.0	2.0
MX 100	411.00	SF	2 3/4	1	10	6 1/8	5 25/32	5 15/32	1 23/32	*	1 15/32	32.0	15.0	2.0
MX 110	457.00	SF	2 3/4	1	11	5 7/8	5 1/2	5 3/16	1 9/16	*	1 3/16	46.0	21.5	3.0
MX 120	529.00	E	3 7/16	1	12 3/8	7 1/4	6 7/8	6 1/2	1 3/4	*	1 1/4	59.8	28.0	3.8
MX 140	918.00	F	3 15/16	2	14 1/8	9 1/2	9 1/16	8 5/8	2 1/16	*	1 3/8	132.5	64.0	4.5
MX 160	1352.00	J	4	2	16 5/8	11 1/2	10 7/8	10 3/8	2 11/16	*	1 3/8	208.7	100.0	8.7
MX 200	2043.00	J	4	2	20	11 3/4	11 5/16	10 13/16	3 5/16	*	1 13/16	366.0	174.0	18.0

→ Maximum bore with keyseat
 * Shaft ends although normally "G" distance apart can project beyond the bushings and be closer together. If this occurs, allow space between shaft ends for endfloat and misalignment.
 ** The MX50 coupling can only be outside-outside mount.

Parts

Flange		Tire	
Flange Part No.	List price \$	Tire Part No.	List price \$
MXF 50	37.00	P50	40.00
MXF 60	52.00	P60	47.00
MXF 70	68.00	P70	65.00
MXF 80	89.00	P80	87.00
MXF 90	121.00	P90	93.00
MXF 100	155.00	P100	101.00
MXF 110	171.00	P110	115.00
MXF 120	200.00	P120	129.00
MXF 140	354.00	P140	210.00
MXF 160	550.00	P160	252.00
MXF 200	790.00	P200	463.00

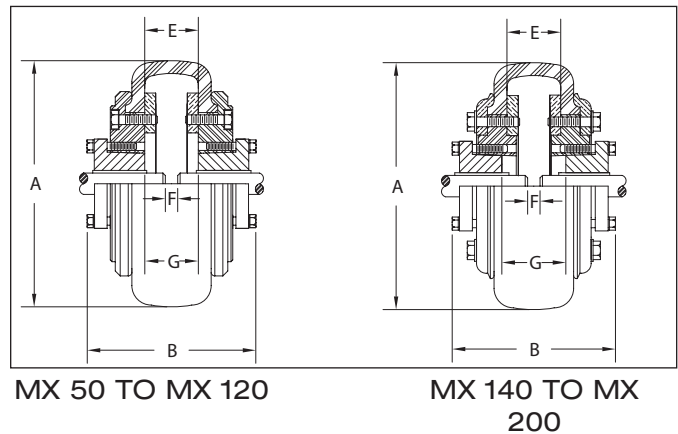

MX 50 TO MX 120

MX 140 TO MX 200

TYPE 1

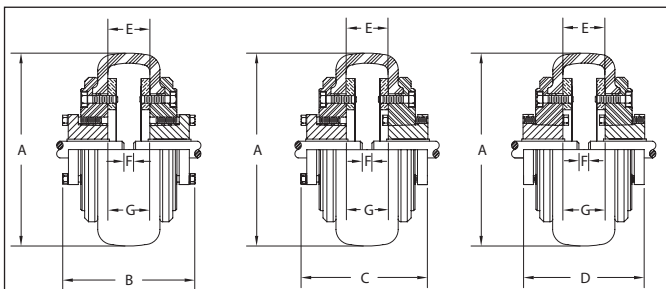

OUTSIDE-OUTSIDE MOUNT

OUTSIDE-INSIDE MOUNT

INSIDE-INSIDE MOUNT

TYPE 2

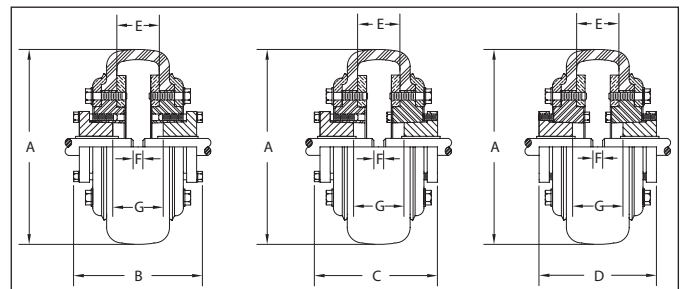

OUTSIDE-OUTSIDE MOUNT

OUTSIDE-INSIDE MOUNT

INSIDE-INSIDE MOUNT

COUPLINGS

COUPLING RATINGS & MISALIGNMENT

Coupling No.	Bush. Size	Max. Bore	Max RPM	HP per 100 RPM Service factors					Torque* @ 1.0 S.F. (LB in)	Average static torsional stiffness coefficient (H)		Approx. WR2 (LB-FT2)	Max. parallel misalignment	Max. axial misalignment
				1.0	1.5	2.0	2.5	3.0		LB-IN/ DEG.	LB-IN/ RAD.			
MX 50	JA	1 1/4	4500	1.43	.95	.72	.57	.48	900	224	12,850	.08	3/64	1/16
MX 60	SH	1 5/8	4000	2.86	1.91	1.43	1.14	.95	1,800	414	23,700	.24	1/16	5/64
MX 70	SDS	1 15/16	3600	3.49	2.33	1.75	1.40	1.16	2,200	544	31,200	.45	5/64	3/32
MX 80	SK	2 1/2	3100	5.71	3.81	2.86	2.28	1.90	3,600	876	50,200	.88	5/64	7/64
MX 90	SK	2 1/2	2800	6.90	4.60	3.45	2.76	2.30	4,350	1,088	62,400	1.60	3/32	1/8
MX 100	SF	2 3/4	2600	8.33	5.55	4.17	3.33	2.78	5,250	1,530	87,700	2.90	7/64	1/8
MX 110	SF	2 3/4	2300	12.30	8.20	6.15	4.92	4.10	7,750	2,420	138,700	4.30	7/64	9/64
MX 120	E	3 7/16	2100	19.90	13.27	9.95	7.96	6.63	12,540	4,014	217,000	6.70	1/8	5/32
MX 140	F	3 15/16	1840	43.78	29.19	21.89	17.51	14.59	27,590	8,296	476,000	19.50	9/64	3/16
MX 160	J	4	1560	59.98	39.99	29.99	23.99	19.99	37,800	12,000	688,000	34.60	11/64	13/64
MX 200	J	4	1300	130.90	87.27	65.45	52.36	43.63	82,500	29,000	1,662,000	103.00	13/64	17/64

* To obtain the maximal torque, multiply by 2.5 the nominal torque. (X-Tork tire)

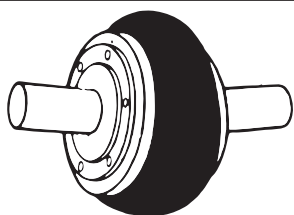

Max. angular misalignment: 4°

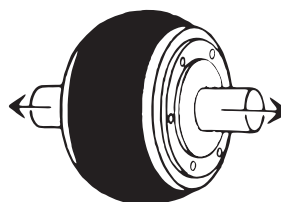

Max. axial misalignment: see Table above

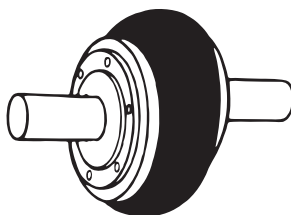

Max. parallel misalignment: see Table above

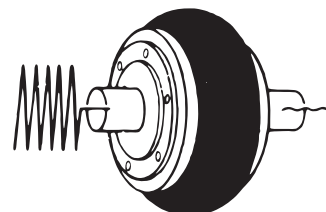

Dampens vibrations



COUPLINGS

**COUPLING SELECTION
- SERVICE FACTORS**



860 RPM MOTORS						
HP	COMPUTER HP / 100 RPM FOR 860 RPM MOTOR	SERVICE FACTOR				
		1.0	1.5	2.0	2.5	3.0
1/2	.058	*50JA	*50JA	*50JA	*50JA	*50JA
3/4	.087	*50JA	*50JA	*50JA	*50JA	*50JA
1	.116	*50JA	*50JA	*50JA	*50JA	*50JA
1 1/2	.174	*50JA	*50JA	*50JA	*50JA	*50JA
2	.232	*50JA	*50JA	*50JA	*50JA	*50JA
3	.349	*50JA	*50JA	*50JA	*50JA	*50JA
5	.581	*50JA	*50JA	*50JA	60SH	60SH
7 1/2	.872	*50JA	*50JA	60SH	60SH	60SH
10	1.16	*50JA	60SH	60SH	70SDS	70SDS
15	1.74	60SH	60SH	70SDS	80SK	80SK
20	2.33	60SH	70SDS	80SK	90SK	100SF
25	2.91	70SDS	80SK	90SK	100SF	110SF
30	3.49	70SDS	80SK	100SF	110SF	110SF
40	4.65	80SK	100SF	110SF	110SF	120E
50	5.81	90SK	110SF	110SF	120E	120E
60	6.98	100SF	110SF	120E	120E	140F
75	8.72	110SF	120E	120E	140F	140F
100	11.63	110SF	120E	140F	140F	140F

1160 RPM MOTORS						
HP	COMPUTER HP / 100 RPM FOR 1160 RPM MOTOR	SERVICE FACTOR				
		1.0	1.5	2.0	2.5	3.0
3/4	.065	*50JA	*50JA	*50JA	*50JA	*50JA
1	.086	*50JA	*50JA	*50JA	*50JA	*50JA
1 1/2	.129	*50JA	*50JA	*50JA	*50JA	*50JA
2	.172	*50JA	*50JA	*50JA	*50JA	*50JA
3	.259	*50JA	*50JA	*50JA	*50JA	*50JA
5	.431	*50JA	*50JA	*60JA	*50JA	*50JA
7 1/2	.647	*50JA	*50JA	*50JA	60SH	60SH
10	.862	*50JA	*50JA	60SH	60SH	60SH
15	1.29	*50JA	60SH	60SH	70SDS	80SK
20	1.72	60SH	60SH	70SDS	80SK	80SK
25	2.16	60SH	70SDS	80SK	80SK	90SK
30	2.59	60SH	80SK	80SK	90SK	100SF
40	3.45	70SDS	80SK	90SK	110SF	110SF
50	4.31	80SK	90SK	110SF	110SF	120E
60	5.17	80SK	100SF	110SF	120E	120E
75	6.47	90SK	110SF	120E	120E	120E
100	8.62	110SF	120E	120E	140F	140F
125	10.78	110SF	120E	140F	140F	140F

COUPLINGS

Bushing sizes shown above may not always have shaft size capacity capabilities.

* 50JA MASKAFLEX couplings are outside-outside mount only.



1750 RPM MOTORS						
HP	COMPUTER HP / 100 RPM FOR 1750 RPM MOTOR	SERVICE FACTOR				
		1.0	1.5	2.0	2.5	3.0
1	.057	*50JA	*50JA	*50JA	*50JA	*50JA
1 1/2	.086	*50JA	*50JA	*50JA	*50JA	*50JA
2	.114	*50JA	*50JA	*50JA	*50JA	*50JA
3	.171	*50JA	*50JA	*50JA	*50JA	*50JA
5	.286	*50JA	*50JA	*50JA	*50JA	*50JA
7 1/2	.429	*50JA	*50JA	*50JA	*50JA	*50JA
10	.571	*50JA	*50JA	*50JA	*50JA	*50JA
15	.857	*50JA	*50JA	60SH	60SH	60SH
20	1.14	*50JA	60SH	60SH	60SH	70SDS
25	1.43	*50JA	60SH	60SH	80SK	80SK
30	1.71	60SH	60SH	70SDS	80SK	80SK
40	2.28	60SH	70SDS	80SK	80SK	90SK
50	2.86	60SH	80SK	80SK	100SF	110SF
60	3.43	70SDS	80SK	90SK	110SF	110SF
75	4.28	80SK	90SK	110SF	110SF	120E
100	5.71	80SK	110SF	110SF	120E	120E
125	7.14	100SF	110SF	120E	120E	140F
150	8.57	110SF	120E	120E	140F	140F
200	11.43	110SF	120E	140F	140F	140F

3500 RPM MOTORS						
HP	COMPUTER HP / 100 RPM FOR 3500 RPM MOTOR	SERVICE FACTOR				
		1.0	1.5	2.0	2.5	3.0
1 1/2	.044	*50JA	*50JA	*50JA	*50JA	*50JA
2	.057	*50JA	*50JA	*50JA	*50JA	*50JA
3	.086	*50JA	*50JA	*50JA	*50JA	*50JA
5	.143	*50JA	*50JA	*50JA	*50JA	*50JA
7 1/2	.214	*50JA	*50JA	*50JA	*50JA	*50JA
10	.286	*50JA	*50JA	*50JA	*50JA	*50JA
15	.429	*50JA	*50JA	*50JA	*50JA	*50JA
20	.571	*50JA	*50JA	*50JA	*50JA	60SH
25	.714	*50JA	*50JA	*50JA	60SH	60SH
30	.857	*50JA	*50JA	60SH	60SH	60SH
40	1.14	*50JA	60SH	60SH	70SDS	70SDS
50	1.428	*50JA	60SH	60SH	--	--
60	1.71	60SH	60SH	70SDS	--	--
75	2.14	60SH	70SDS	--	--	--
100	2.86	60SH	--	--	--	--
125		--	--	--	--	--
150		--	--	--	--	--
200		--	--	--	--	--
250		--	--	--	--	--

Bushing sizes shown above may not always have shaft size capacity capabilities.
 * 50JA MASKAFLEX couplings are outside-outside mount only.