

Industrial Belt Tension Tester Instructions

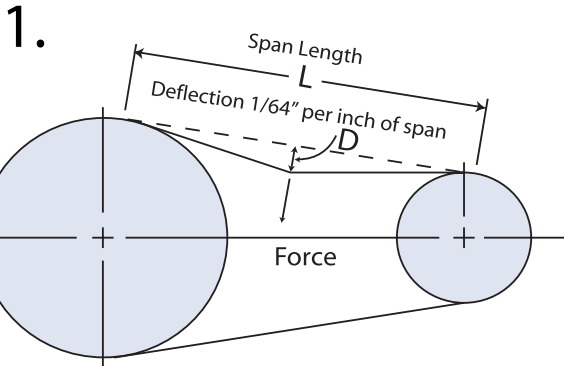

Model: AWI-1
Force Range: 0-35 lbs. (0-15.9 kg)
Tension Range: 0-560 lbs. (0-255 kg)

Description: An industrial belt tension tester capable of testing force and belt tension on single strand belts, within the above ranges, on belts to 1» in width.

Capabilities: Recommended for use on «3V-3VX», «5V-5VX» and those «8V» belts which have force ranges below 35 lbs. Additionally, can handle «A», «B», «C» and all other single-strand belts within the above force ranges.

Operation (Theory): Uses the universally accepted method of determining belt tension by depressing the belt 1/64" per inch of span. This results in an «F» over «T» ratio of 1 to 16. The maximum tension capability of this instrument therefore is 16 X 35, or 560 lbs.

Operation: (Practice)

- 1- Measure the length of span from sheave tangent points («L» in picture).
- 2- Set the bottom of the large «0» ring at the correct point (on «50» if it is a 50" span) and set the top (small «0» ring) down against the instrument's flange.
- 3- Depress the instrument downward at the center of the span until the large «0» ring at the base of the instrument is in line with the tangent point of the drive («D» in picture). (This may be accomplished with a straight-edge, or a neighbouring belt, in a multiple-belt drive.)
- 4- Read the number of pounds of force indicated by the small «0» ring on the plunger rod and multiply by 16 to determine belt tension.

Note: Many belt manufacturers will specify the recommended plunger reading, in lbs. or kg., for a specific application. In such cases, always follow the belt manufacturers' recommendations.

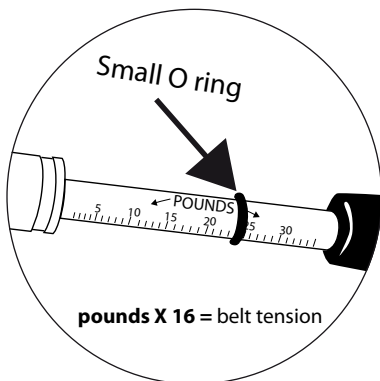
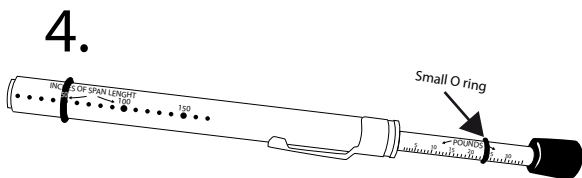
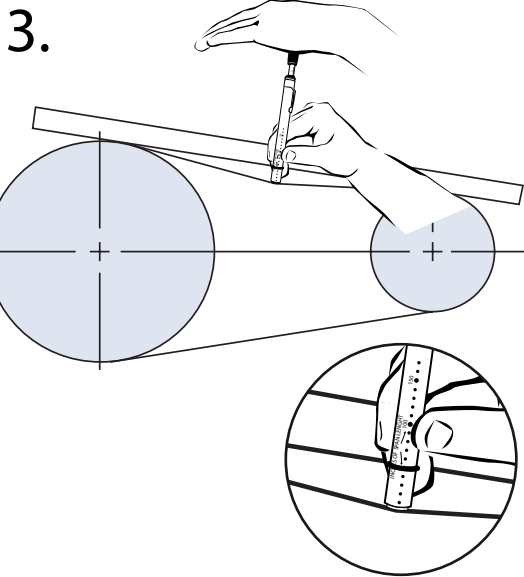
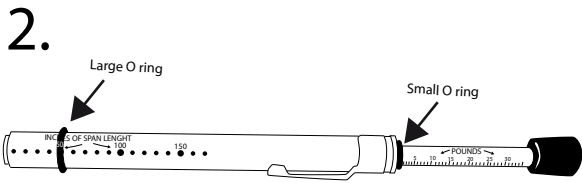

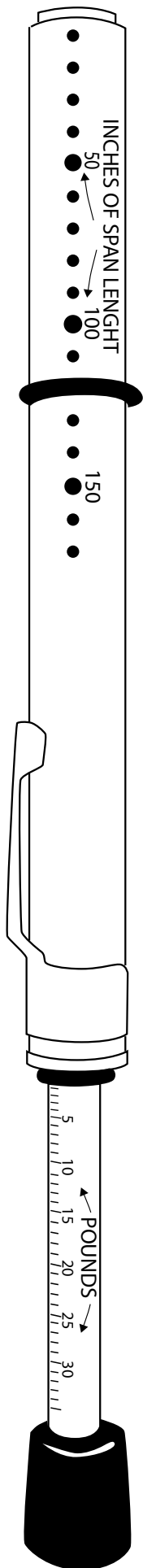

**Standard V-Belt
Tensioning Deflection Force**

Belt Cross-Section	Smaller Pulley Diameter Range (in.)	Deflection Force	
		Run-in (lbs.)	Normal (lbs.)
A	3.0-3.6	3-3/8	2-1/4
	3.8-4.8	4-1/4	2-7/8
	5.0-7.0	5-1/8	3-3/8
AX	3.0-3.6	4-1/8	2-3/4
	3.8-4.8	5	3-1/4
	5.0-7.0	6	4
B	3.4-4.2	4	2-5/8
	4.4-5.2	6	4
	5.4-9.4	7-1/8	5-1/4
BX	3.4-4.2	5-1/4	3-1/2
	4.4-5.2	7-1/8	4-3/4
	5.4-9.4	9	6
C	7.0-9.0	11-1/4	7-1/2
	9.5-16.0	15-3/4	10-1/2
CX	7.0-9.0	13-1/2	9
	9.5-16.0	17-1/2	11-3/4
D	12.0-16.0	24-1/2	16-1/2
	18.0-22.0	33	22
E	21.6-27.0	48	32
3V	3.40-4.20	6	4
	4.20-10.6	7	5
3VX	2.20-3.65	7	5
	4.12-10.6	8	6
5V	7.10-10.9	16	8-12
	11.8-16.0	20	10-15
5VX	4.40-10.9	18	10-14
	11.8-16.0	22	12-18
8V	12.5-17.0	36	18-27
	18.0-22.4	40	20-30

**Synchronous Belt
Tensioning Deflection Force**

Belt Pitch	Belt Width	Deflection Force
Synchron. 8MM (14mm)	20mm	2 to 4 lbs
	30mm	3 to 6 lbs
	50mm	7 to 11 lbs
	85mm	11 to 19 lbs
Synchron. 14MM (14mm)	40mm	5 to 11 lbs
	55mm	8 to 17 lbs
	85mm	14 to 27 lbs
	115mm	20 to 40 lbs
MXL (.080-in.)	170mm	30 to 60 lbs
	1/8-inch	1 oz
	3/16-inch	1 - 1-1/2 oz
	1/4-inch	2 oz
XL (1/5-in.)	5/16-inch	2 - 2-1/2 oz
	3/8-inch	3 oz
	3/8-inch	3-1/2 oz
L (3/8-in.)	1/2-inch	7 oz
	3/4-inch	11 oz
	1-inch	1 lb
H (1/2-in.)	3/4-inch	2 lbs
	1-inch	2-1/2 lbs
	1-1/2-inch	4 lbs
	2-inch	5-1/2 lbs
XH (7/8-in.)	3-inch	8-1/2 lbs
	2-inch	7-1/2 lbs
	3-inch	11-1/2 lbs
XXH (1-1/4-in.)	4-inch	16-1/2 lbs
	2-inch	9 lbs
	3-inch	14 lbs
	4-inch	20 lbs
	5-inch	26 lbs

**V-Ribbed Belt Tensioning
Deflection Force**

Belt Cross Section	Small Sheave Diameter range	Force "F" Lbs. Per Rib
J	1.32-1.67	0.4
J	1.77-2.20	0.5
J	2.36-2.95	0.6
L	2.95-3.74	1.7
L	3.94-4.92	2.1
L	5.20-6.69	2.5
M	7.09-8.82	6.4
M	9.29-11.81	7.7
M	12.40-15.75	8.8